

## CT-3001

Highly compact, high-speed, electrically driven radial turbo compressor with air bearings for the air supply of fuel cell systems.

- High-speed gas bearings for oil-free operation
- Lowest ratio of volume and weight versus pressure and mass flow due to highest speeds
- Aerodynamic and electromagnetic optimization for highest total efficiency
- Integrated temperature measurement for overload protection
- Compatible to converter CC-3000 / CC-3001



### Specifications turbo compressor

Maximum pressure ratio	2.7
Maximum mass flow	210 g/s
Maximum isentropic overall efficiency <sup>1</sup>	69 %
Maximum speed	130,000 rpm
Maximum converter input power	21 kW
Weight	18.5 kg (excl. cable)
Dimensions (L x W x H)	370 x 192 x 215 mm (14.6 x 7.6 x 8.5 inch)

### Cooling

Coolant	50% / 50% water glycol mixture
Coolant temperature	-20 – 55 °C
In-/Outlet connector type	According to SAE J1231 430192
Tube ID	16 mm

### Electrical interface

Connection type	Motor and sensor connector
Motor connector	Amphenol / PowerLok 4.0
Sensor connector	Amphenol / Eco-Mate RM

<sup>1</sup>Isentropic overall efficiency including aerodynamic, motor and bearing efficiency

All rights reserved. All information in this document is based on Celeroton's best knowledge and is not to be considered as a warranty or quality specification. The information given is designed as a guidance and customers are requested to check the suitability and usability of the product in their specific application with consulting Celeroton. The information herein is subject to change without notification.

**Compressor map: operation with converter CC-3001**

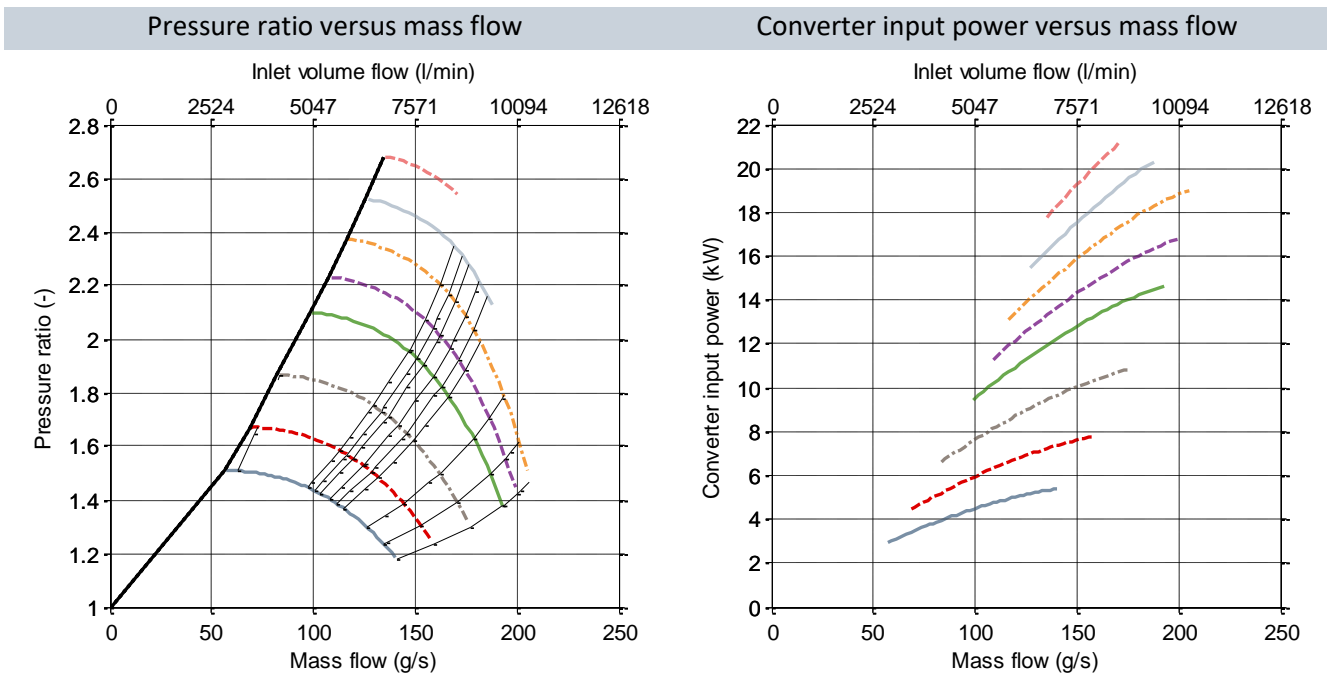

**Order codes: CT-3001**

Ordering information	Article number
CT-3001	Contact Celeroton
CC-3000 (200 – 450 VDC)	Contact Celeroton
CC-3001 (400 – 750 VDC)	Contact Celeroton

All rights reserved. All information in this document is based on Celeroton's best knowledge and is not to be considered as a warranty or quality specification. The information given is designed as a guidance and customers are requested to check the suitability and usability of the product in their specific application with consulting Celeroton. The information herein is subject to change without notification.

Drawing in mm [inch]

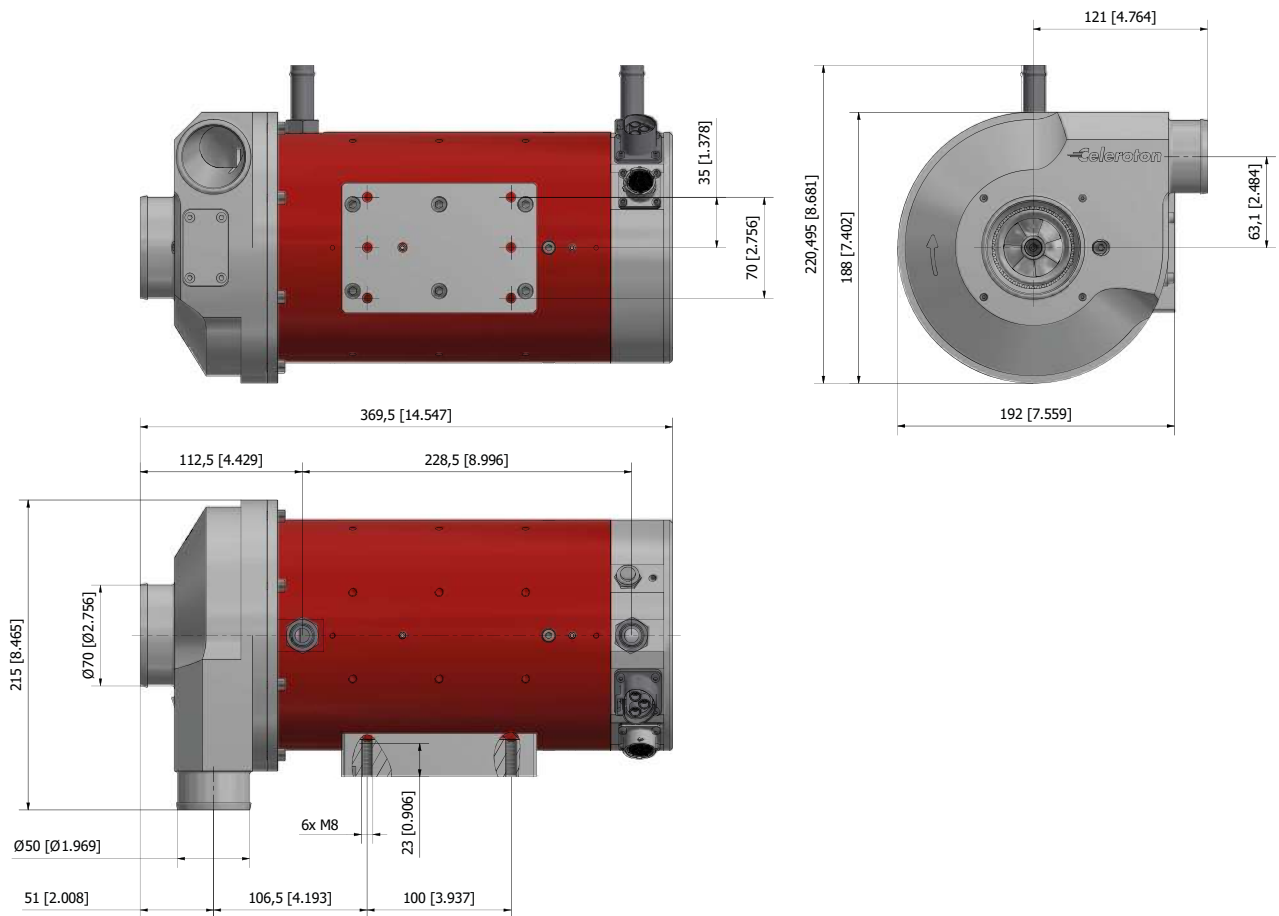

The specifications and compressor maps in this document refer to air (ISO 8778) at the inlet of the compressor: temperature:  $T = 20^{\circ}\text{C}$ , absolute pressure:  $p_{in} = 1 \text{ bar}$ .



Depending on ambient and operation conditions, the compressor maps shown in this document may be different or may have additional limitations.

For technical details and further information, please refer to the user manual or contact Celeroton directly.